

SINGLE SIDED TABLET PRESS



Technical Details - GMP Model

MODEL	STATIONS	MAX. PRESSURE IN TONS	ROUND TABLET MAX. DIA	CAPLET MAX LENGTH	PUNCH			DIE			MOTOR		TABLET OUTPUT PER HOUR	
					TYPE	DIA	HEIGHT	TYPE	DIA	HEIGHT	HP	RPM	MIN	MAX
ASR D-D-16	16	10.0	25.0	25	D	25.40	133.6	D	38.10	23.81	5	1500	4800	48000
ASR D-D-20	20	10.0	25.0	25	D	25.40	133.6	D	38.10	23.81	5	1500	6000	60000
ASR D-B-23	23	10.0	19.0	21	D	25.40	133.6	B	30.16	22.22	5	1500	6900	69000
ASR D-B-26	26	10.0	19.0	NA	D	25.40	133.6	B	30.16	22.22	5	1500	7800	78000
ASR B-B-26	26	6.5	18.5	19	B	19.05	133.6	B	30.16	22.22	5	1500	7800	78000
ASR B-BB-32	32	6.5	13.0	NA	B	19.05	133.6	BB	24.00	22.22	5	1500	9600	96000

* R&D Turret can also be offered with combination of D, B & BB tooling.

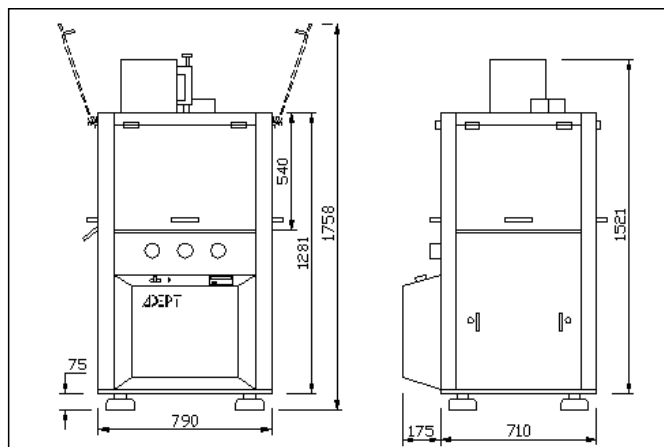

- Max fill depth - 21mm
- Upper punch entry - 1.5 to 8mm
- Hopper capacity - 15 liters
- Net weight - 1000 kg
- Gross weight - 1250 kg
- Overall dimensions - 88cm x 84cm x 162cm
- Case dimensions - 115cm x 35 cm x 115 cm